



DC-UPS 150 WATT SERIES

MODELS COVERED: DC-UPS 24-70 & DC-UPS 12-70



Document Number: dc-ups/70guide-a

NOTES

TABLE of CONTENTS

1.0 – INTRODUCTION	5
2.0 – PRODUCT DESCRIPTION	6
3.0 – APPLICATIONS	7
4.0 – THEORY of OPERATION	8
4.1 – LINE-UP MODE	
4.2 – LINE-DOWN MODE	
4.3 – TEMPERATURE COMPENSATION	
4.4 – LOAD VOLTAGE	
5.0 – SPECIFICATIONS	10
ELECTRICAL & OPERATING SPECIFICATIONS	
REPLACEABLE PARTS	
OVERALL DIMENSIONS	
SHIPPING DATA	
6.0 – SYSTEM DESIGN	12
6.1 – INPUT SURGE PROTECTION	
6.2 – BATTERY TYPE GUIDELINES	
6.3 – BATTERY VENTILATION / ENCLOSURES	
6.4 – BATTERY SIZING	
6.5 – BATTERY SIZING GRAPHS	
7.0 – INSTALLATION	15
7.1 – LOCATION	
7.2 – MOUNTING	
7.3 – WIRING	
8.0 – OPERATION	18
8.1 – INITIAL POWER-UP	
8.2 – NORMAL OPERATION	
8.3 – TROUBLESHOOTING	
9.0 – MAINTENANCE	21
9.1 – BATTERY MAINTENANCE	
9.2 – BATTERY REPLACEMENT	
10.0 – WARRANTY	22

1.0 – INTRODUCTION

Solis Energy is a Manufacturing and Engineering Company providing electric power solutions, both as components and systems, for a broad array of applications. Our solar and line-powered systems provide reliable service to a wide range of critical power needs in the industrial control, oil and gas, telemetry, communications, marine, vehicle, portable and remote power industries. Whether standard or custom, all of Solis Energy's products bring industrial quality and high reliability to our customers.

This guide covers the DC-UPS 150 Watt Series component. Complete DC-UPS SYSTEMS, including batteries, enclosures and a space for your electronics are also available. If you need more information, or find errors or omissions in this manual, please contact Solis Energy at (407) 339-6786 or info@SolisEnergy.com.

2.0 – PRODUCT DESCRIPTION

The DC-UPS 70 Watt Series is a modular component; designed to be combined with a storage battery. This combination provides clean, uninterrupted power to critical 12 and 24 volt DC loads supplied from AC mains. In the event of AC (utility) power loss, back-up power can be provided for hours, days, or even weeks depending on the load and battery capacity.

The DC-UPS is both a battery charger and a primary DC power supply. It replaces the conventional power supply used in DC powered systems. It replaces the battery charger used in scratch-built back-up systems. Both of these approaches have drawbacks. Conventional power supplies are poor battery chargers and battery chargers are poor power supplies. The DC-UPS solves these problems and saves time with many well integrated and unique features:

- **True Universal Input** – 47-66 Hz, 85-265 VAC continuous (no jumpers); 110-370 VDC input allows many options in system design.
- **Power-factor-corrected Input** – prevents harmonic degradation of the AC power line feeding the system.
- **150 Watt Total System Power Output** – with 70 watts available for load power and 80 Watts or more for fast battery charging.
- **Constant-current Limited Output** – avoids the shutdown, fold-back and tripping problems common when conventional power supplies are used for battery charging.
- **Temperature Compensated Output** – provides proper voltage for battery maintenance over wide temperature extremes. This feature is not found in conventional power supplies.
- **Low Noise Output** – allows use with sensitive electronics used in control, monitoring, and communication applications. A feature not commonly found in battery chargers.
- **Glitch-less Switch-over** – powered directly from the system battery, provides continuous load power free of sharp transients.
- **Wide Operating Temperature** – of -20 - +60° C (-4 - +140° F) makes it suitable for indoor or outdoor use.
- **Input and Output Magnetic Circuit Breakers** – provide precise protection, safety and convenience over broad temperature ranges.
- **Isolated Form C Alarm Contacts** – provide remote signaling or shed un-needed loads when AC power fails.
- **Status Indicators** – provide system status at a glance and aid with troubleshooting.
- **Reverse Battery Protection** – with a replaceable fuse protects the DC-UPS and your loads from costly damage.
- **Convenient Mounting** – allows the DC-UPS to be flat panel or DIN rail (35mm) mounted.
- **Rugged Enclosure / Quality Construction** – to provide years of trouble-free service in harsh industrial or remote applications.

3.0 – APPLICATIONS

The DC-UPS is effectively used in a wide range of safety, security, and critical applications. Some of these are:

- **Wireless Access Points** – continuous communications.
- **SCADA Systems** – are more reliable with long-term back-up power.
- **Tower and Obstruction Lighting** – beacons stay flashing during an outage.
- **Remote Telemetry** – tolerates huge voltage drops from long power lines.
- **Video Cameras** – keep on seeing when the power goes out.
- **Gate Openers** – provide continued access during a power outage or storm.
- **Security Systems** – never miss a beat when the power is cut.
- **Roadway Caution Signs** – continue working when needed most.
- **Radio Base Stations & Repeaters** – with large batteries maintain vital communication during natural disasters.
- **LED Traffic Controls** – maintain traffic flow during an outage.
- **DC Industrial Controls** – use back-up power for control and monitoring on the factory floor.
- **WAN/LAN Back-up Power** – keeps communications up and running.
- **Grid-tie Solar Systems** – charge 12 or 24 volt batteries with high voltage DC.
- **Low Voltage Lighting** – stays lit and provides safety on walkways, stairs, and mezzanines.

4.0 – THEORY of OPERATION

The DC-UPS is built around a switching power supply with a wide range AC / DC power-factor corrected input. The output of the supply is rectangular-current-limited ideal for battery charging; and the charging voltage is temperature compensated.

The DC-UPS has isolated form C alarm contacts for remote signaling that indicate line power status.

Magnetic circuit breakers are provided on both the line input and load output. Indicators for Input, Alarm, and Load show visual system status. A replaceable fuse and voltage clamp protect the DCUPS and the load equipment against reverse battery hook-up.

The DC-UPS has 2 modes of operation: "LINE-UP", when line power is present, and "LINE-DOWN", when line power is missing.

4.1 – LINE-UP Mode

Please see Fig. 4.1.1. In LINE-UP mode, the power supply delivers 13.8 Volts nominal for 12 Volt systems, or 27.6 Volts nominal for 24 Volt systems, to the battery and load. Power is divided between the battery and load based on which requires the most current (lowest impedance). Power to the load is always limited by the output breaker to 70 Watts. Under light load conditions, the full 150 Watts produced by the power supply is available for battery charging.

In the LINE-UP mode, the alarm contacts are closed in the N.C. position. Fig. 4.1.1 shows the current path for the alarm circuit. The AC indicator is lit and the ALARM indicator is dark.

Figure 4.1.1 – Operation in LINE-UP Mode.

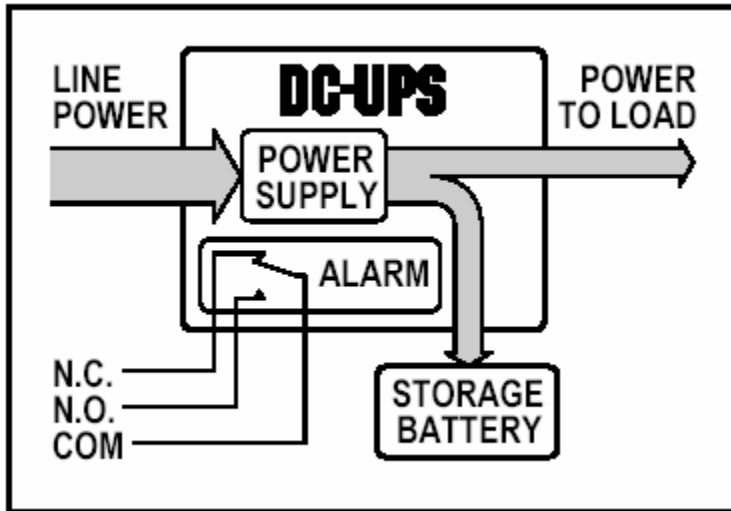

4.2 – LINE-DOWN Mode

See Fig. 4.2.1. In LINE-DOWN mode, the power supply delivers no power. All load power is supplied by the battery.

In the LINE-DOWN mode, the alarm contacts are closed in the N.O. position. Fig. 4.2.1 shows the current path for the alarm circuit. The AC indicator is dark and the ALARM indicator is lit.

Figure 4.2.1 – Operation in LINE-DOWN Mode.

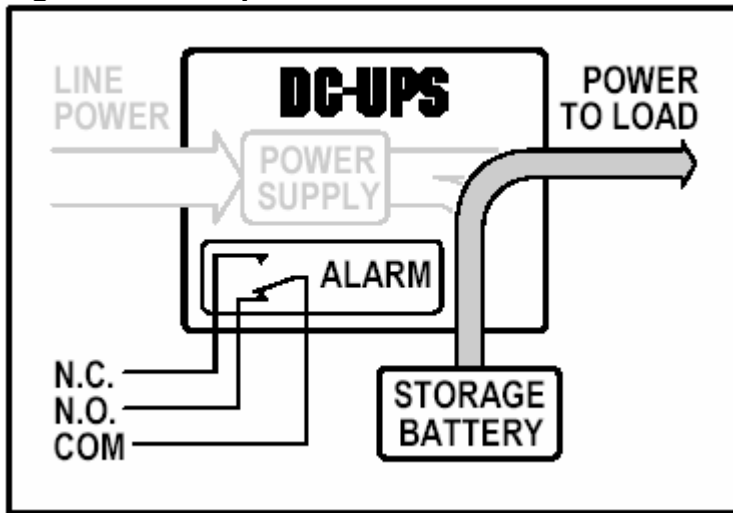

4.3 – Temperature Compensation

Batteries are damaged by prolonged under-charging or over-charging. The correct voltage for battery charging depends on temperature. Low temperatures require a higher voltage to avoid under-charging. High temperatures require a lower voltage to avoid over-charging. Outdoor systems have the widest temperature extremes. **To extend the life of the battery, the DC-UPS is temperature compensated. It adjusts the maximum charge voltage according to the temperature of the battery.**

4.4 – Load Voltage

At all times, the load voltage is essentially equal to the battery voltage. All variations due to state-of-charge and temperature compensation are passed directly to the load. Some sensitive electronic equipment cannot tolerate the wide voltage range over which batteries operate. **The load equipment input must be designed for the normal range of battery voltage, 11 – 15 Volts for 12 volt systems, 22-30 Volts for 24 Volt systems.**

Applications requiring precise input voltage should use a DC-DC converter with a regulated output. These converters provide a stable voltage to the load regardless of battery voltage.

5.0 – SPECIFICATIONS

Table 5.0.1 – Electrical & Operating Specifications

PARAMETER	DC-UPS 12V-70W			DC-UPS 24V-70W			UNIT
	Minimum	Typical	Maximum	Minimum	Typical	Maximum	
INPUT							
AC Input Voltage	85	—	265	85	—	265	Volts RMS
Input Frequency	47	—	66	47	—	66	Hertz
Power Factor Correction	0.95	—	—	0.95	—	—	n/a
DC Input Voltage	110	—	370	110	—	370	Volts
OUTPUT – Battery & Load							
Battery & Load Voltage at 25°C	13.7	13.8	13.9	27.4	27.6	27.8	Volts
Battery & Load Voltage Over 0 – 60°C (temp. comp. range)	12.9 (60°C)	—	14.9 (0°C)	25.8 (60°C)	—	29.8 (0°C)	Volts (ambient temp.)
Output Voltage Temperature Compensation (0 – 60°C only)	—	-0.025	—	—	-0.05	—	Volts / °C
Battery Charging Current (no load)	—	—	10.5	—	—	5.25	Amps
Load Current (70 Watts)	—	—	5	—	—	2.5	Amps
Load Current (140 Watts)	—	—	10	—	—	5	Amps
Output Switching Noise	—	—	100	—	—	100	mV p-p
GENERAL							
Operating Temperature	-20	—	60	-20	—	60	°C
Efficiency	75	—	—	78	—	—	%
EMC – Emissions							
Radiated Noise: 30mHz – 1gHz per FCC Class B							
Conducted Noise: 150kHz – 30mHz per FCC Class B							
ALARM CONTACTS							
DC Current Rating at 30 VDC max	—	—	1	—	—	1	Amps
AC Current Rating at 120 VAC max	—	—	0.3	—	—	0.3	Amps

NOTES:

1. These values apply at minimum input voltage conditions.

2. The stated voltages refer to system in LINE-UP mode with a fully charged battery. If the battery has been recently discharged the system will operate in current limited mode until the battery regains full charge. When the battery is less than fully charged, the output voltage will be lower than the stated values. In LINE-DOWN mode, the load voltage is roughly equal to the battery voltage. Battery voltage will be a function of state of charge, temperature and overall condition. In both modes of operation the LOAD voltage will be as much as 0.2 Volts (0.4 Volts for 24 Volt systems) lower than the battery voltage because of the parasitic voltage drop across the output circuit breaker.

3. The system battery has a significant damping effect on noise; typical output noise will be much lower.

Table 5.0.2 – Replaceable Parts

REPLACEABLE PARTS	DC-UPS 70 SERIES	PART NUMBER
Battery Protection Fuse	15 Amp 3AG Fast-Blow	Littlefuse p/n 312015 Bussman p/n AGC-15

Table 5.0.3 – Overall Dimensions

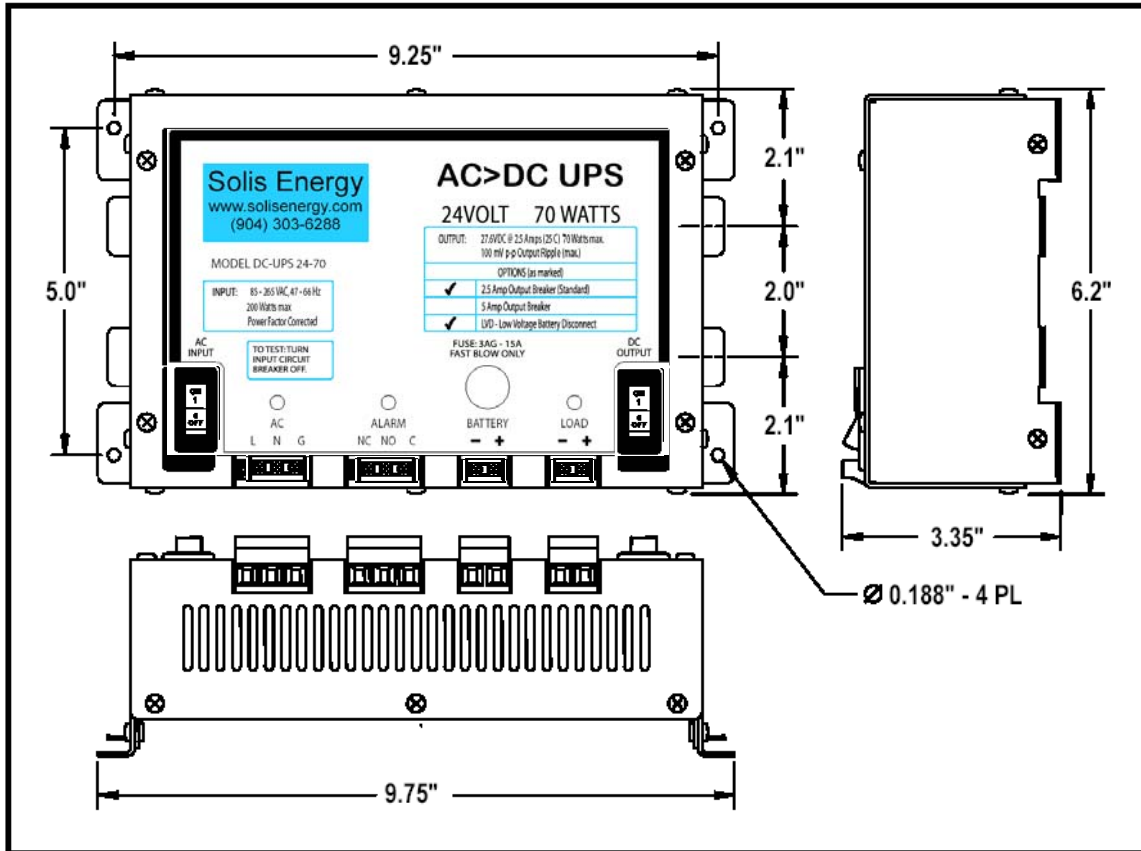

Table 5.0.4 – Shipping Data

PARAMETER	DC-UPS 70 SERIES			UNIT
	MIN.	TYP.	MAX.	
WEIGHTS & DIMS				
Weight	—	3	—	lbs.
Shipping Weight	—	5	—	lbs.
Shipping carton size	—	11.5 x 9 x 5	—	Inches
Shipping volume	—	0.3	—	cubic feet
Storage temperature	-30 (-22)	—	80 (176)	°C (°F)

Note: Specifications are subject to change without notice. The most recent version of this document is available at www.solisenergy.com/dc-ups/70guide.pdf.

6.0 – SYSTEM DESIGN

The design of a complete DC-UPS system is simple. All that is required is selection of the proper batteries. Convenient graphs for this are provided.

6.1 – Input Surge Protection

Although the DC-UPS has some built in surge protection, it is often desirable to use an input surge protector as insurance against unwanted high voltage input surges. Systems in remote areas are especially prone to lightning-induced damage. Input surge protection available from Solis Energy can be used on the input power line of the DC-UPS for additional surge protection.

6.2 – Battery Type Guidelines

The DC-UPS is specifically designed for deep cycle lead-acid batteries. It will work with either Gel or AGM maintenance-free batteries. It should **NOT** be used with wet lead-acid batteries, automotive batteries, or nickel-cadmium batteries.

6.3 – Battery Ventilation / Enclosures

Batteries should never be placed inside a sealed enclosure or area because they will vent explosive gases during charging. While the quantities of gas are generally quite small, a sealed area allows the concentration of hydrogen to exceed safe levels. For outdoor applications, the batteries should be placed in a vented enclosure along with the DCUPS. Solis Energy offers a variety of enclosure options for the DC-UPS, many of them feature NEMA 3R/4X construction, with a vented battery compartment and a sealed electronics compartment, separated by a welded bulkhead. If your specifications require a NEMA 4 enclosure, be sure to include a one-way battery vent to allow explosive battery gasses to escape.

6.4 – Battery Sizing

The DC-UPS will work with a wide variety of battery capacities listed in the table 6.4.1.

Table 6.4.1 – Min / Max Battery Capacities

Parameter	MODEL	
	DC-UPS 12-70	DC-UPS 24-70
Min. Bat. Cap.	34 Amp-hours	17 Amp-hours
Max. Bat. Cap.	400 Amp-hours	200 Amp-hours

The correct battery capacity for your system will depend on two factors: your load; and the length of time you wish to have back-up power. The larger the battery, the longer the back-up period or "HOLDUP" time will be. The "RECOVERY" time as well as the system cost increases as well. Your actual battery capacity should be calculated by multiplying your **average** load in Amps (A) times the number of hours (h) of back-up desired, plus a safety factor of 1.5 (SF). The safety factor is important as it takes into account a cold battery, or a battery at the end of its life.

$$\text{Battery Capacity} = A \times h \times SF$$

Thus a 1A load with a desired back-up time of 48 hours with a 1.5 safety factor will require a 72Ah battery. $1A \times 48h \times 1.5 = 72Ah$ When combining batteries in series or parallel, it is important to know the rules for determining the total capacity of the battery bank:

- 1. When combining batteries in parallel, add the battery's capacities to arrive at the total.**
- 2. When combining batteries in series, do not add the capacities. The total capacity equals the capacity of one battery in the series string.**

Figure 6.4.2 shows an example of some typical battery banks and their capacities:

Figure 6.4.2 – Battery Banks

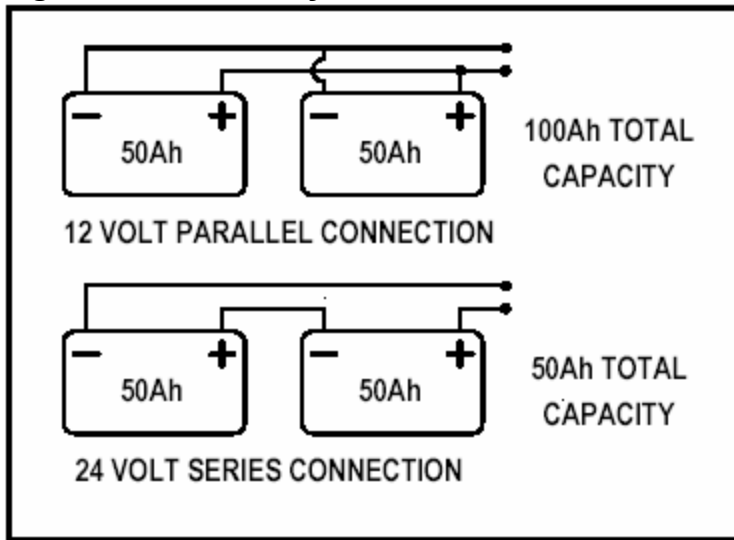

6.5 – Battery Sizing Graphs

These graphs can be used to determine the required battery capacity and the resulting RECOVERY time for the system.

RECOVERY time is the time required for the battery to recover a full state of charge. RECOVERY occurs while the load is drawing full current. In lightly loaded systems, the RECOVERY time may be much less.

Figure 6.5.1 – Battery Capacity vs. Average Load Current & Hold-up Time

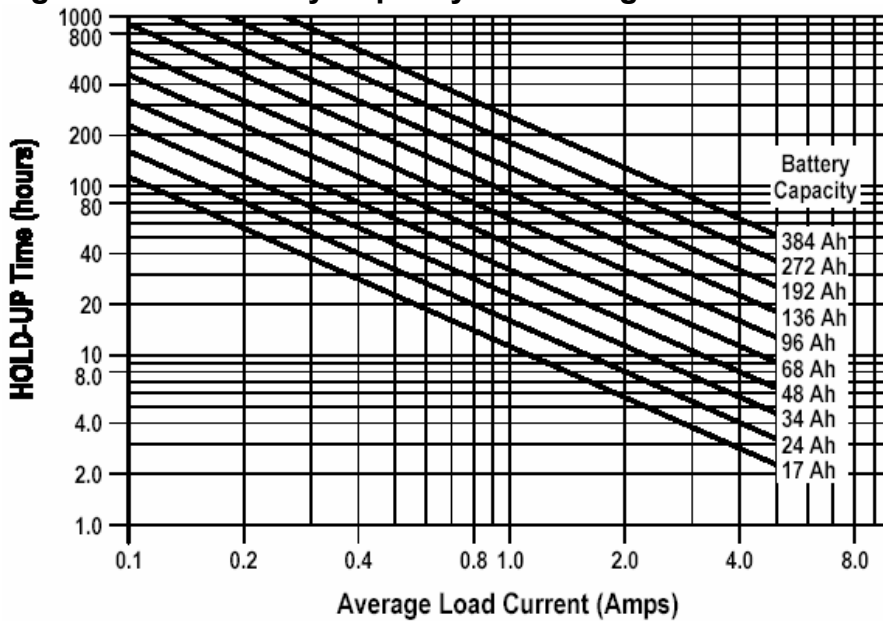

Average Load Current (Amps)

To determine the minimum required Battery Capacity:

1. Draw a vertical line through the Average Load Current.
2. Draw a horizontal line through the desired HOLD-UP Time.
3. Mark the intersection.
4. Find the next Battery Capacity line above the intersection and read the value at the right.

Note: This graph has a 1.5 Safety Factor built in.

Figure 6.5.2 – Recovery Time vs. Average Load Current & Battery Capacity

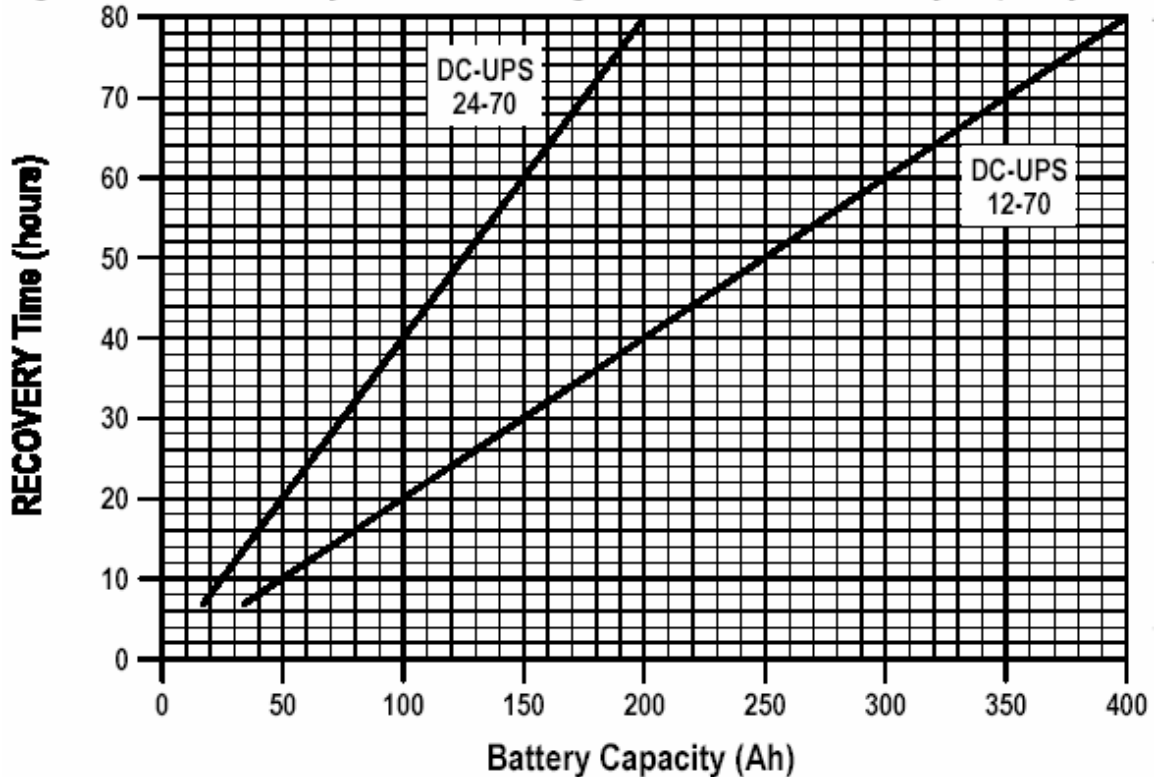

Battery Capacity (Ah)

To determine the maximum RECOVERY time:

1. Draw a vertical line through the Battery Capacity.
2. Mark where this line intersects the line for the model of DC-UPS.
3. From this intersection, read the value at the left.

Note: This graph has a 1.2 Safety Factor built in.

7.0 – INSTALLATION

Multiple mounting methods and cage-clamp terminals make installation simple and fast.

7.1 – Location

Enclosures used for mounting should be ventilated to prevent heat build-up. **Do not mount the DCUPS, or the system battery, in direct sunlight, in corrosive environments, or near generators or other sources of extreme heat.**

The DC-UPS senses the air temperature and adjusts the battery's charge voltage. Because of this, the unit should be located close to the battery to sense the battery's temperature. For enclosure applications, mount the unit about 6" or less above the battery. For indoor applications mount the unit in the same room, over the battery.

7.2 – Mounting

The DC-UPS can be mounted on flat panels or standard 35mm DIN rails. For proper ventilation, the unit should be mounted in a vertical position, with the label vertical and the text horizontal. As shown in the figures below, at least 1" of clearance should be allowed above and below the unit for airflow. **Do not block the ventilation holes on the top, back, and bottom of the unit.**

To mount the unit on a flat panel, drill holes and use #8 screws to secure. See Fig. 7.2.1 below for dimensions.

Figure 7.2.1 – Flat Panel Mounting

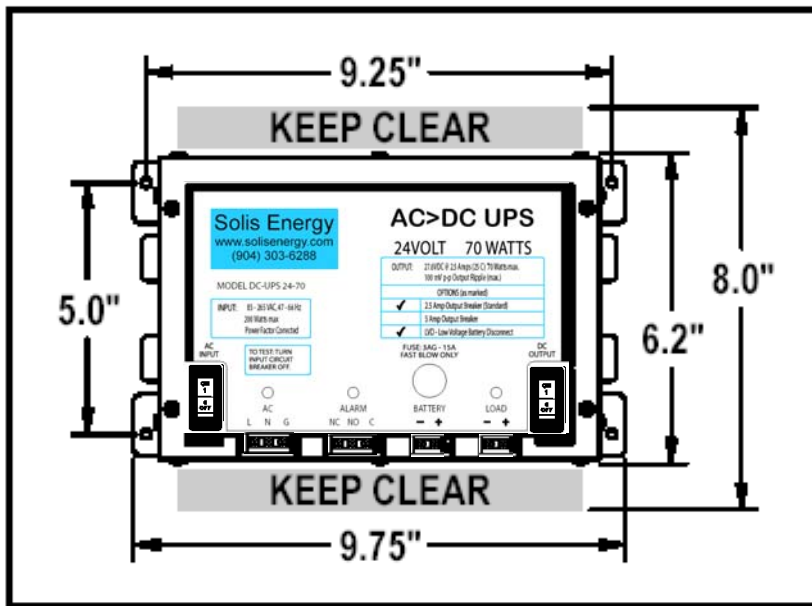

To mount the unit on DIN rail, place the unit in position with the mounting tabs nested inside the DIN rail, snap 2 standard end-stops over the rail and tighten the screw. There are 2 positions possible with DIN-style mounting, high and low. See Figs. 7.2.2 & 7.2.3 for dimensions.

Figure 7.2.2 – High Position DIN Mounting.

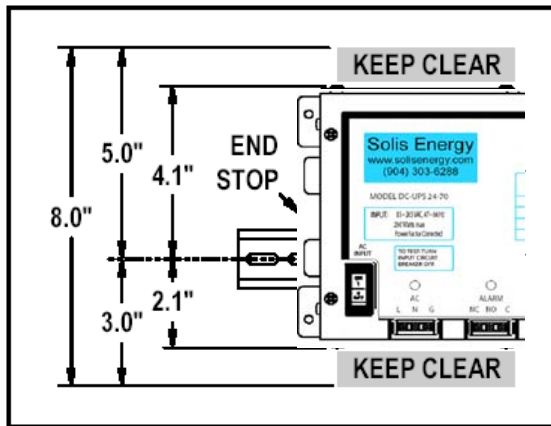
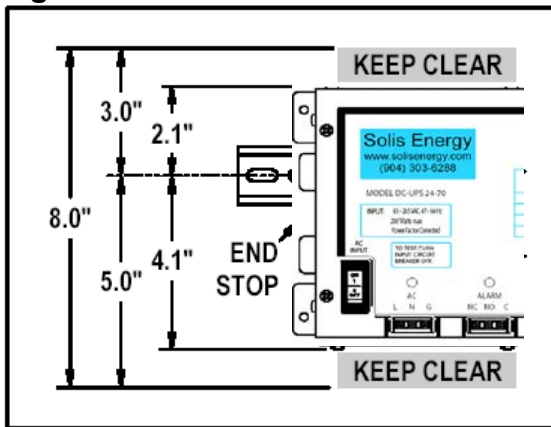

Figure 7.2.3 – Low Position DIN Mounting.



7.3 – Wiring

Follow all local and National Electrical Code guidelines when wiring this device. Stranded wire is recommended for all connections in the UPS system. The following wire sizes are recommended:

- Line / Input Wiring – 12-14 AWG
- Alarm wiring – 18-22 AWG
- Battery Wiring – 10-12 AWG
- Load / Output Wiring – 12-14 AWG

Always leave some slack in the wires before cutting to length. All connections to the DC-UPS are made in the same way:

1. Carefully strip 1/4 – 3/8” of insulation from the wires. Twist the strands tightly and neatly following the natural twist of the wires.
2. Unscrew the cage-clamp screw about 10 turns. This insures the jaws of the clamp are open.
3. Insert the wire into the terminal opening making sure no strands are splayed out. Tighten the screw. Do not use excessive force.
4. Tug on the wire to verify a secure connection. Follow the Wiring Diagram in Figure 7.3.1 to make all connections. **Pay close attention to the battery wiring.**

1. **With mains power and the INPUT breaker OFF**, make connections to the AC input. The “N” terminal should be used for L2 in high voltage AC systems. In DC powered systems, the “N” terminal should be used for the negative polarity and the “L” for the positive.

2. Make the alarm connections, if used.
3. **With the positive wire AT THE BATTERY disconnected**, make the battery connections to the DC-UPS. Double check polarity, and make the final connection at the positive battery terminal last. There will be small spark as the unit draws a small current from the battery. **REVERSE HOOK-UP WILL BLOW THE FUSE.**
4. **With the OUTPUT breaker OFF**, make the load connections, again checking for correct polarity.
5. See Section 8.1 for Power-up information.

Figure 7.3.1 – Wiring Diagram

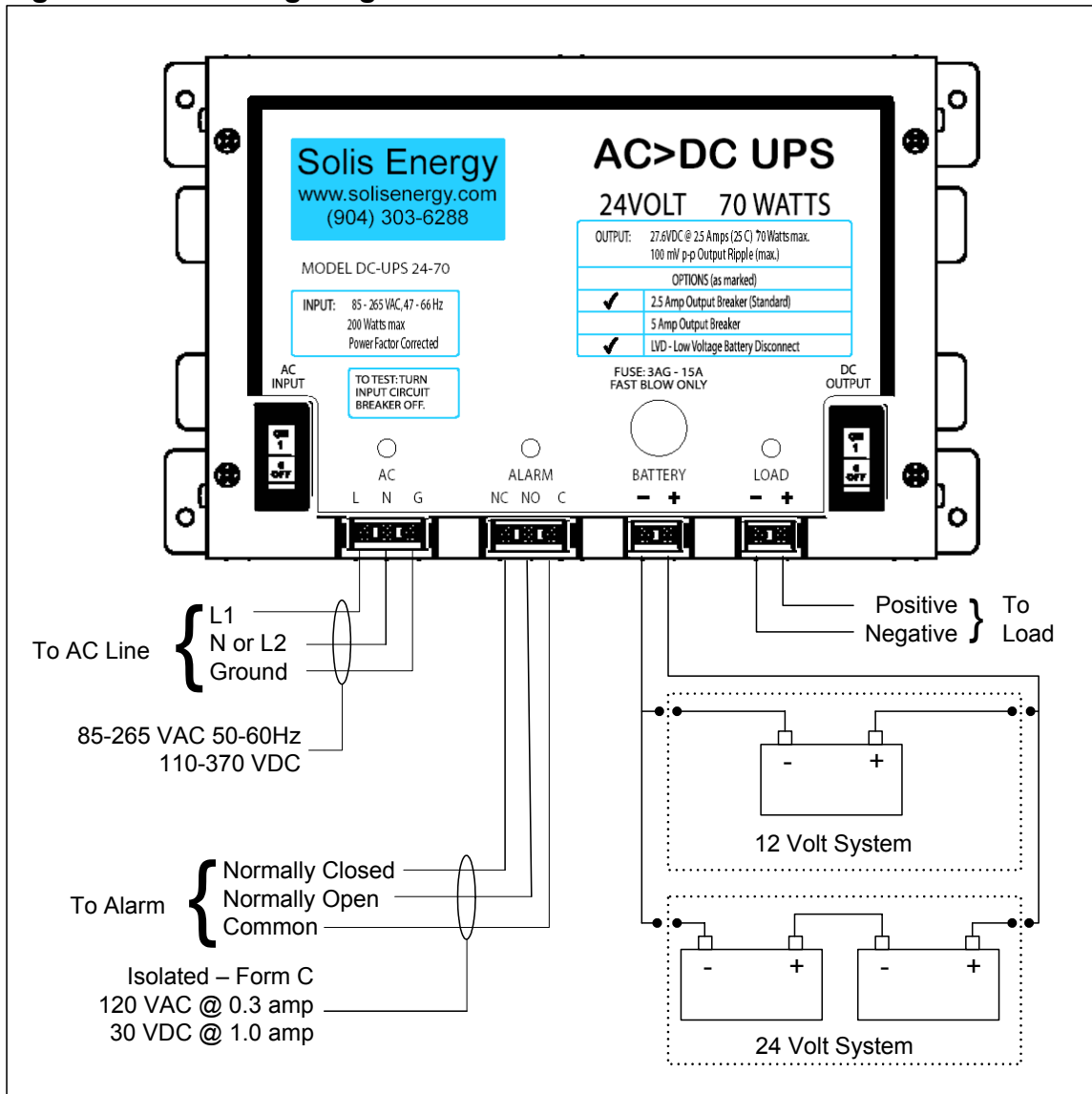

8.0 – OPERATION

Figure 8.0.1 – General View

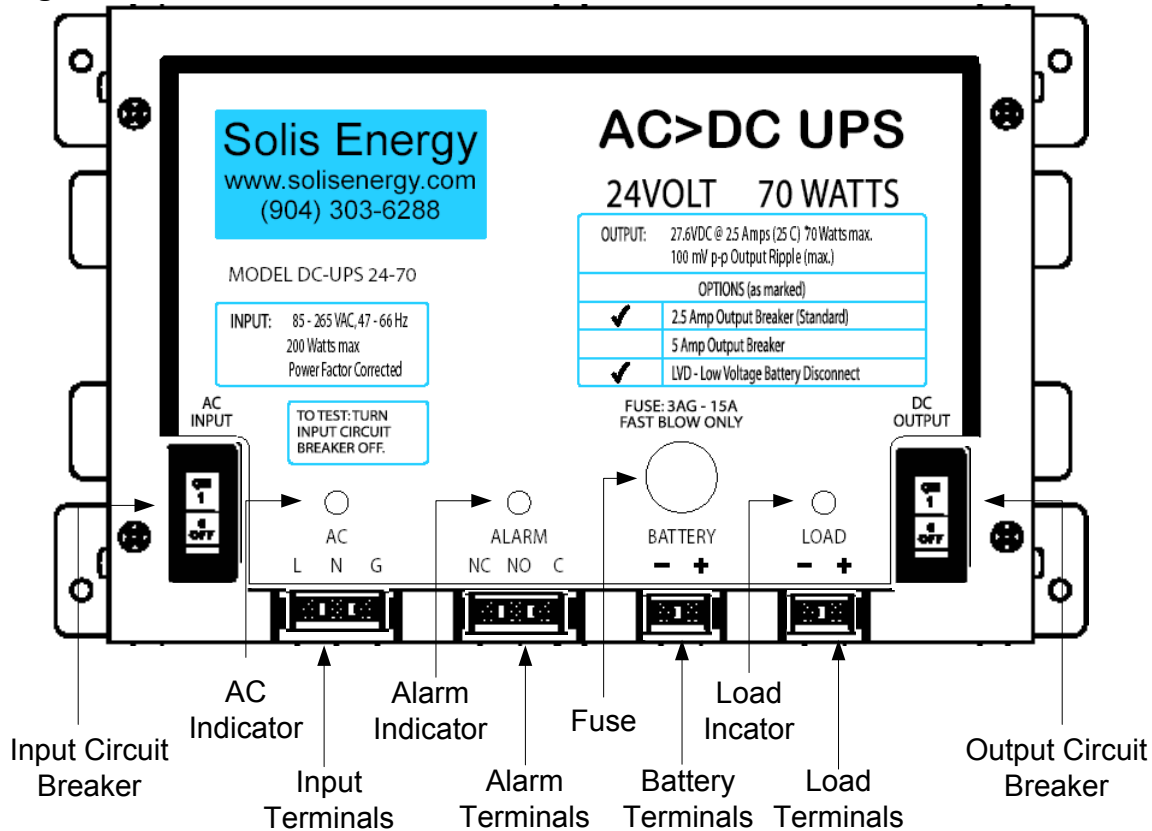

8.1 – Initial Power-up

This procedure provides a quick check to verify the system is wired and functioning correctly. With the system wired completely as in Section 7.3:

1. Turn the INPUT & OUTPUT breakers OFF:

- The AC indicator should be dark.
- The ALARM indicator should be lit.
- The LOAD indicator should be dark.

2. Turn the OUTPUT breaker ON:

- The AC indicator should be dark.
- The ALARM indicator should be lit.
- The LOAD indicator should be lit

3. Turn the INPUT breaker ON:

- The AC indicator should be lit.
- The ALARM indicator should be dark.
- The LOAD indicator should be lit.

8.2 – Normal Operation

In normal operation, LINE-UP mode, both the AC and LOAD indicators should be lit and the ALARM indicator should be dark. The DC-UPS is supplying energy to charge the battery and power the load. The battery voltage should either be: at the maximum charging voltage, about 13.8 Volts for a 12 Volt system, 27.6 Volts for 24 Volt system; or rising slowly to these levels. These voltages vary with temperature, lower at high temperatures, higher at low temperatures.

In back-up operation, LINE-DOWN mode, the AC indicator should be dark and both the ALARM and LOAD indicators should be lit. The battery is supplying the energy to the load. The battery voltage should be falling slowly.

In either mode, you may monitor the battery voltage to check the charging function. Generally, a rising voltage indicates a charging battery while a falling voltage indicates a discharging battery. If the system has a large battery capacity, these changes may occur too slowly to observe. If so, record the voltage and allow several minutes or hours and check the voltage again.

If you suspect the system is not functioning properly, see the troubleshooting points in Section 8.3.

8.3 – Troubleshooting

The following is a list of problems you may experience and the most likely remedy:

The INPUT breaker trips and will not reset:

- Check the incoming voltage. The voltage across terminals L and N should be less than 265 VAC or 370 VDC. Excessive input voltage will damage the DC-UPS.

The AC indicator fails to light with the INPUT breaker ON:

- Check the incoming voltage. The voltage across terminals L and N should be at least 85 VAC or 110 VDC.
- Check for a shorted battery or battery wiring. Examine the battery wiring, if good remove the positive connection at the battery. If the AC indicator lights, the battery is defective.

The ALARM indicator fails to light with the INPUT breaker OFF:

- Check the battery wiring for shorts.
- Check the battery for proper voltage at least 11.5 Volts for a 12 Volt system and 23 Volts for a 24 Volt system. If the battery voltage is less than this; the battery is probably defective or worn out.
- Check the fuse.

The battery fails to charge while the AC indicator is lit:

- Check the fuse.
- Check the battery wiring.
- Check the battery; the battery may be defective or worn out.

The LOAD indicator fails to light with the OUTPUT breaker ON:

- Check the battery for low voltage.
- Check the fuse.

The OUTPUT breaker trips and will not reset:

- Check the load wiring and polarity.
- Check for a shorted load.
- Check for excess load current.

The load fails to operate properly:

- Check the polarity of the load connections.
- Check the voltage at the load.
- Determine if the load requires a regulated 12 or 24 volt output. If so, a DC/DC converter should be used at the load output.
- The load equipment may be faulty.

The DC-UPS is generating heat:

- This heat is normal. The DC-UPS will generate more heat, as much as 30 Watts, after power is restored due to heavy battery charging.

NOTE - Because batteries charge and discharge slowly, diagnosing battery problems in the field can be difficult. As batteries age their capacity drops and the ability to store energy is lost. Despite this, faulty batteries can still draw charge current and develop voltage. A worn out battery can sometimes appear good. A proper method for testing a battery consists of bringing the battery to the fullest state of charge possible, and then discharging the battery and measuring the energy delivered. While time consuming, this method can be employed in the field. If the battery can supply the load for the desired time; it can be deemed good. If the battery will not accept charge or cannot deliver the required energy; it is worn out. In many circumstances it may be more economical to replace a suspect battery rather than perform a full charge-discharge test. If the troubleshooting points above do not locate the cause of the problem, please call, email, or write Solis Energy for assistance before returning the DCUPS unit. We have years of experience troubleshooting power systems and can usually solve problems over the phone.

Customer Service at:

Solis Energy Inc.
927 Fern St. Suite 1200
Altamonte Springs, Florida 32701
(407) 339-6786
info@SolisEnergy.com

9.0 – MAINTENANCE

The DC-UPS is maintenance free. The batteries used in the system will require maintenance and eventual replacement.

9.1 – Battery Maintenance

Gel or AGM batteries require little maintenance. However, all system connections should be checked once a year for corrosion. Corrosion, if any, usually occurs at the battery terminals or posts. Corrosion should be removed and the connections cleaned:

1. **Use protective eyewear and gloves.**
2. Turn the INPUT and OUTPUT breakers OFF.
3. Disassemble the corroded components and remove the corrosion with a stainless steel wire brush. The metal parts should be bright.
4. Reassemble the connections. The connections are soft metal; do not over-tighten.
5. Wait several minutes then re-tighten the battery connections.
6. Turn the INPUT and OUTPUT breakers ON.

NOTE: For systems showing signs of corrosion, it is recommended that a corrosion inhibiting grease is applied to the terminals after final tightening.

9.2 – Battery Replacement

Most Gel and AGM batteries require replacement after approximately 5 – 7 years of standby service at the ideal temperature of 75°F (25°C). Generally, batteries in outdoor enclosures and hot climates last from 3 to 5 years.

Because battery temperatures, usage, and quality vary from site to site, we make no recommendations regarding replacement intervals for batteries. It is generally accepted that a lead acid battery should be replaced when it falls below 80% of its rated capacity, at the factory specified rate of discharge. You may perform the test described at the end of Section 8.3 to determine if your battery has sufficient capacity for your application. Hold-up (discharge) and recovery times are shown in Graphs 6.5.1 and 6.5.2 in Section 6.5.

Lead and other materials used in batteries are toxic and present hazards to our environment. These materials also have value and can be recycled. Nearly all recycling facilities accept batteries. Comply with all Federal, State, and local regulations when disposing of batteries.

Please recycle!

10.0 – WARRANTY

WARRANTY

Solis Energy (Seller) warrants to the original purchaser that the DC-UPS product is free from defects in materials and workmanship for a period of 1 year from the date of purchase. If the DC-UPS (Equipment) is found to be defective during the warranty period, Solis Energy agrees to repair or replace the Equipment, at its' option.

You must call (904) 303-6288 to receive instructions and an RMA number to obtain repair or replacement.

This warranty shall not apply if this equipment is: (a) materially modified or tampered with, (b) is damaged by acts of God, misuse, negligence, accident, unreasonable use, or by other causes unrelated to defective material or workmanship. Repair or replacement of this product as provided under this warranty is the exclusive remedy of the buyer. Any applicable implied warranties, including warranties of merchantability and fitness for a particular purpose, are expressly limited in duration to the duration of this warranty. In no event shall Seller be liable for consequential or incidental damages for breach of any express or implied warranty on the equipment. Some states or provinces do not allow the exclusion or limitations of consequential or incidental damages, so the above limitations or exclusions may not apply to you.